

Caproni

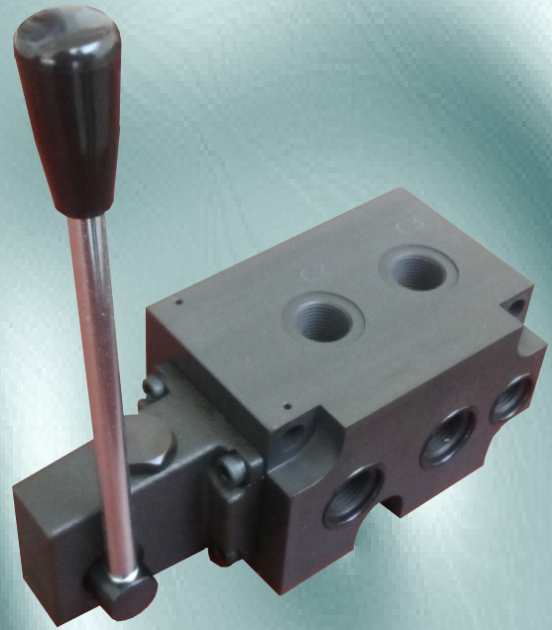

FLOW DIVERTERS

CONTENTS:

Page

3/2FDV06...1 - electrical control 1/11...3/11

6/2FDV06...1 - electrical control 4/11...6/11

6/2FDV06...7 - manual control 7/11...11/11

GENERAL DESCRIPTION

- ✓ 3/2- way flow diverter with solenoid operation
- ✓ Removable DC voltage coils-quick replacement and rotation in any direction without leakage from the system
- ✓ Wet pin core tubes
- ✓ Manual override option (push button)
- ✓ Maximum control of hydraulic power
- ✓ Reliability and long life



Connecting example

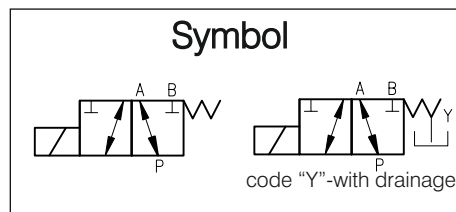
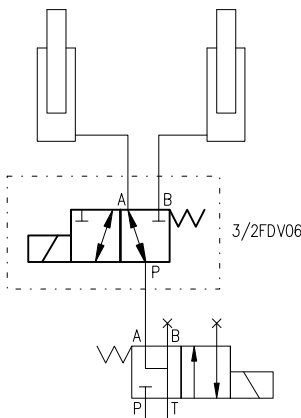

The 3/2FDV06... valve is solenoid operated flow diverter valve. It is often used to control the direction of flow with two single acting cylinders as shown in the connecting example.

In case of problem with the electric supply , an option for manual override is provided.

ORDERING CODE

3/2 FDV 06 1A 1 - .../... F

3-way , 2-position

Flow diverter

Nominal size - NG6

Functional symbol

Type of control: -electrical

Supply voltage/current frequency: 12V DC - **012/00**
24V DC - **024/00**

Modification

External drainage:

omit - without drainage
Y - with drainage

Connection threads:

G38 - G3/8"
G12 - G1/2"

Climatic executions:

N - normal
T - tropical

Connectors:

C1 - without connector
C2 - standard connector
C3 - connector with light indicator

TECHNICAL DATA
GENERAL

DATA	UNIT	VALUE/RANGE
Installation position		optional
Max. ambient temperature	°C	-20...+50
Weight	kg	1,700

HYDRAULIC

Max. pressure:		MPa	31,5
with drainage			21
without drainage			
Rated flow - see characteristics			
Hydraulic fluid-mineral oil:			
-viscosity	mm ² /s		10...800
-filtration degree	mm		0.025
-temperature	°C		-20...80

ELECTRICAL

Cyclic duration		%	100
Waterproof			IP65
Heat insulation			H
Type of voltage			DC
Available voltage /frequency		V/Hz	12/00 24/00
Voltage tolerance		%	±10
Current consumption	12VDC 24VDC	A	3,1 1,6
Max. switching frequencies		cycle/h	10000

DIMENSIONS

All dimensions are shown in mm.

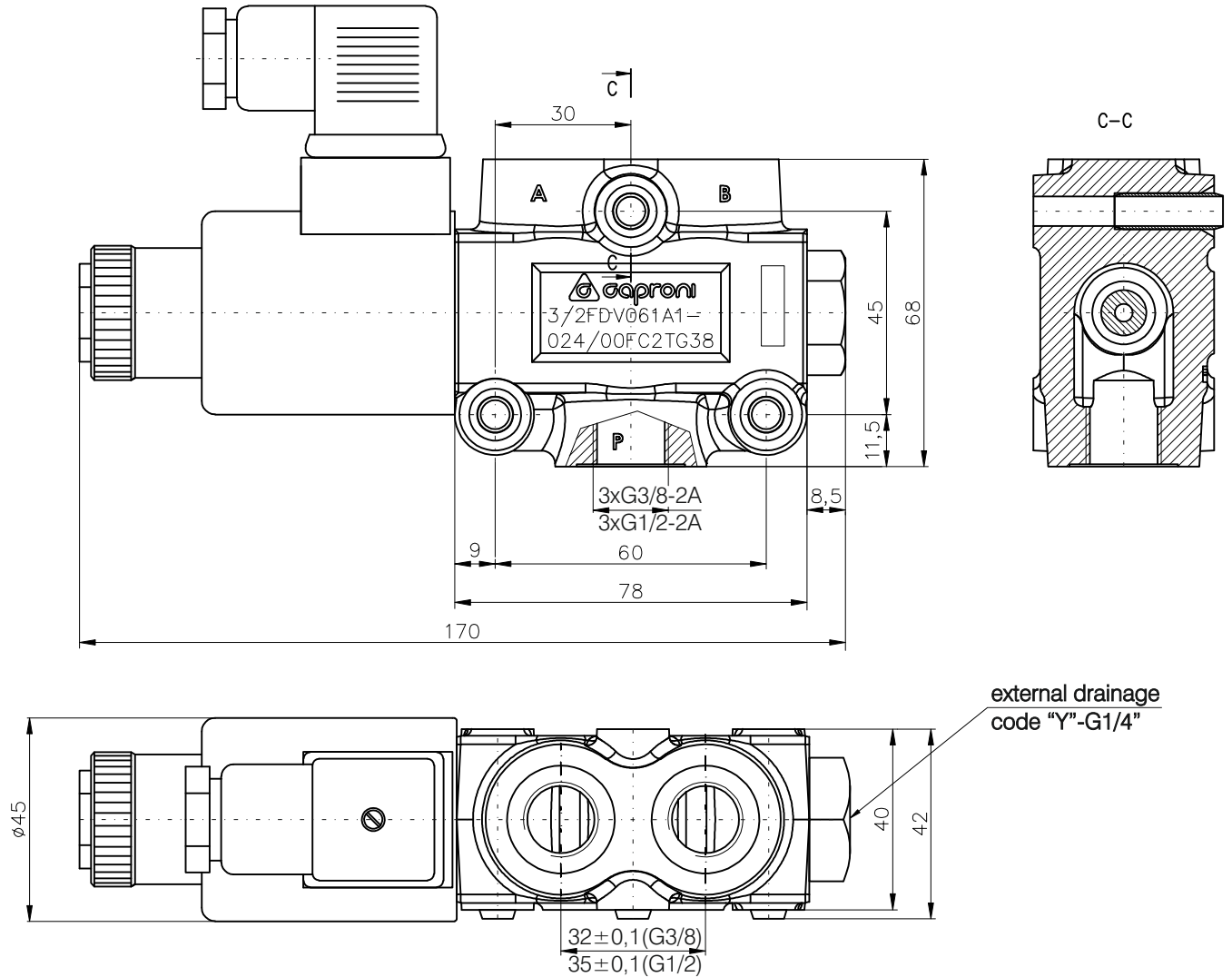

CHARACTERISTICS

p/Q

curve 2 - P to A and P to B
 curve 1 - A to P and B to P
 32cSt oil at 50°C ; measured for valve without drainage

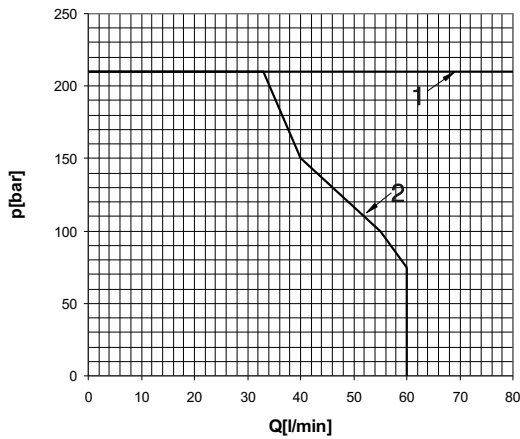

$\Delta p/Q$

P to A , P to B , A to P and B to P
 32cSt oil at 50°C

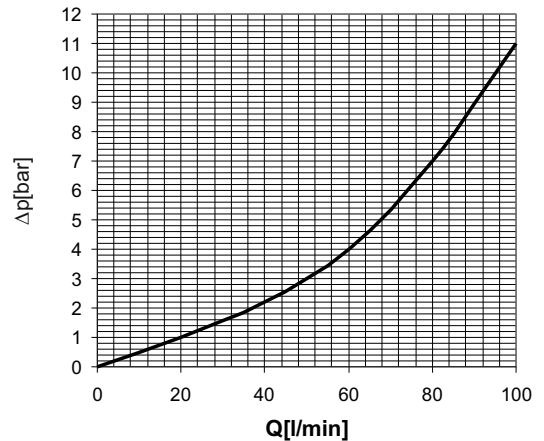

GENERAL DESCRIPTION

- ✓ 6/2- way flow diverter with solenoid operation
- ✓ Removable DC voltage coils-quick replacement and rotation in any direction without leakage from the system
- ✓ Wet pin core tubes
- ✓ Manual override option (push button)
- ✓ Maximum control of hydraulic power
- ✓ Reliability and long life

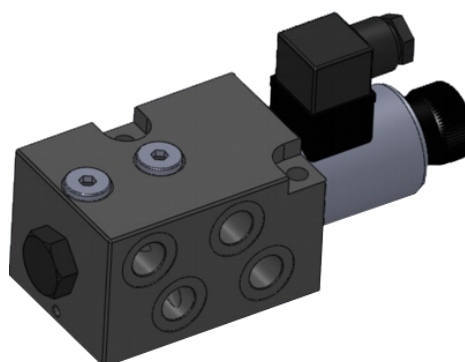

Connecting example

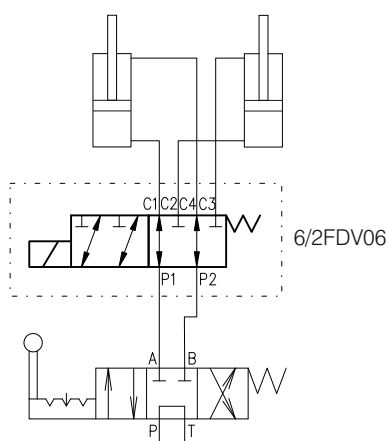

	Symbol	Intermediate	Drainage
11A			code "Y"- with drainage
12A			code "Y"- with drainage
11A			without drainage
12A			without drainage

The 6/2FDV06... valve is solenoid operated flow diverter valve. It is often used to control the direction of flow with two double acting cylinders as shown in the connecting example.

In case of problem with the electrical supply , an option for manual override is provided.

ORDERING CODE

6/2 FDV 06 ... 1 - .../... F

6-way , 2-position

Flow diverter

Nominal size - NG6

Functional symbol: **11A**
12A

Type of control: -electrical

Supply voltage/current frequency: 12V DC - **012/00**
24V DC - **024/00**

Modification

Connectors:

- without connector - **C1**
- standard connector - **C2**
- connector with light indicator - **C3**

External drainage:

omit - without drainage
Y - with drainage

Connection threads:

G38 - G3/8"
M18 - M18x1,5

Climatic executions:

N - normal
T - tropical

TECHNICAL DATA
GENERAL

DATA	UNIT	VALUE/RANGE
Installation position		optional
Max. ambient temperature	°C	-20...+50
Weight	kg	3,300

HYDRAULIC

Max. pressure: with drainage without drainage	MPa	31,5 21
Rated flow - see characteristics		
Hydraulic fluid-mineral oil: -viscosity -filtration degree -temperature	mm ² /s mm °C	10...800 0.025 -20...80

ELECTRICAL

Cyclic duration	%	100
Waterproof		IP65
Heat insulation		H
Type of voltage		DC
Available voltage /frequency	V/Hz	12/00 24/00
Voltage tolerance	%	± 10
Current consumption 12VDC 24VDC	A	3,1 1,6
Max. switching frequencies	cycle/h	10000

DIMENSIONS

All dimensions are shown in mm.

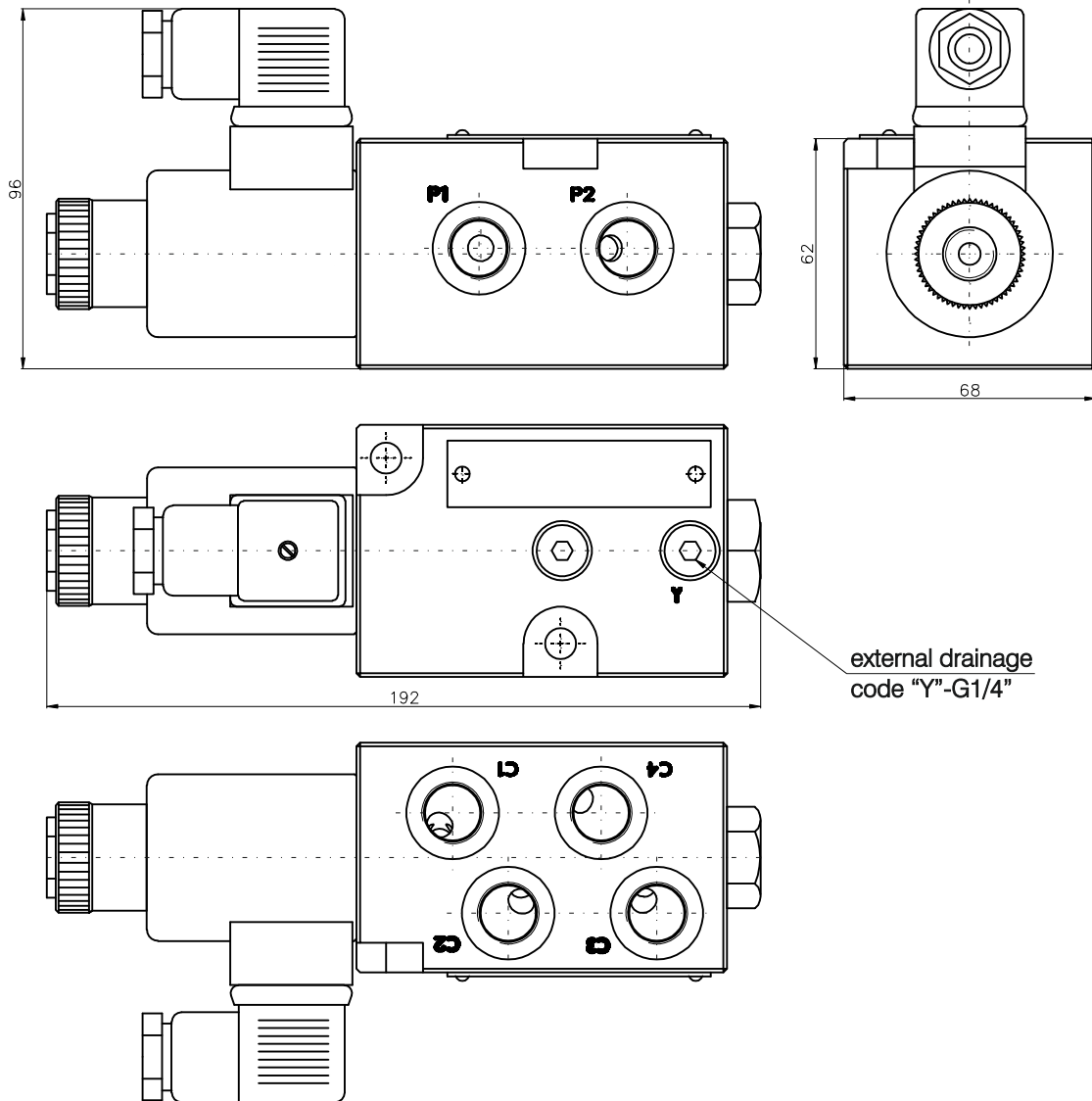

CHARACTERISTICS

p/Q

$\Delta p/Q$

curve 2 - P1 to C2 to C3 to P2 & P2 to C3 to C2 to P1
 curve 1 - P1 to C1 to C4 to P2 & P2 to C4 to C1 to P1
 32cSt oil at 50°C ; measured for valve without drainage

For all directions
 32cSt oil at 50°C

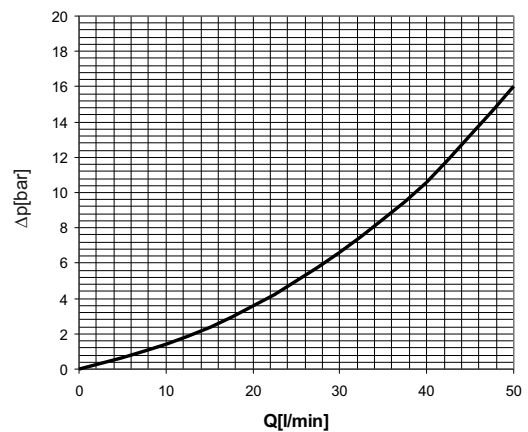
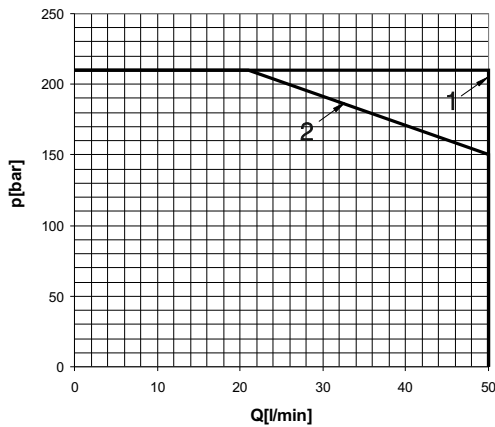

GENERAL DESCRIPTION

- ✓ 6/2- way flow diverter with manual operation
- ✓ Maximum control of hydraulic power
- ✓ Reliability and long life

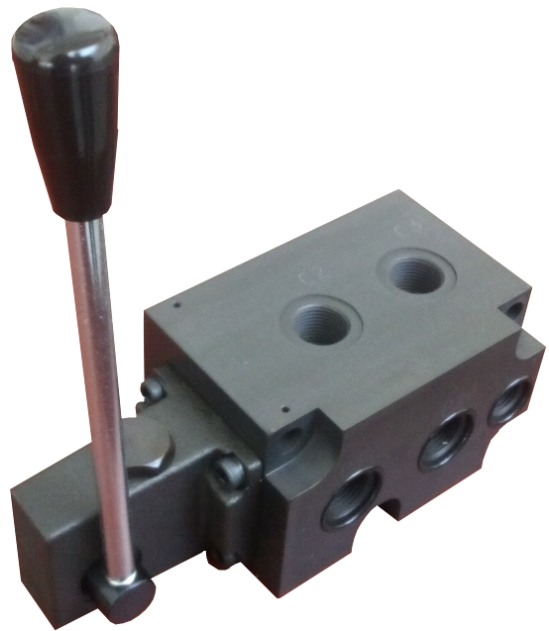

Symbol	Intermediate	Drainage
11A		code "Y"- with drainage
12A		code "Y"- with drainage
11A		without drainage
12A		without drainage

The 6/2FDV06-7... valve is manual operated flow diverter valve. It is often used to control the direction of flow for two or more double acting cylinders as shown in the connecting examples.

CONNECTING EXAMPLES

single connection
(one valve)

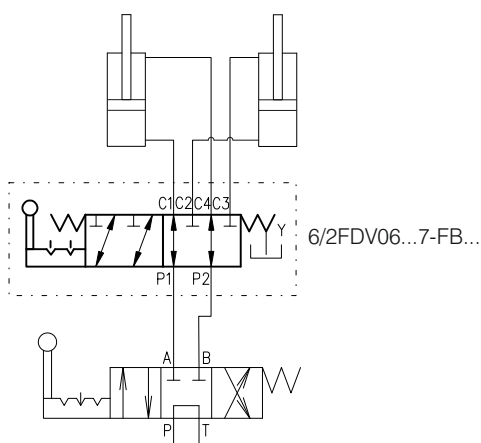

stackable connection
(up to 5 valves)

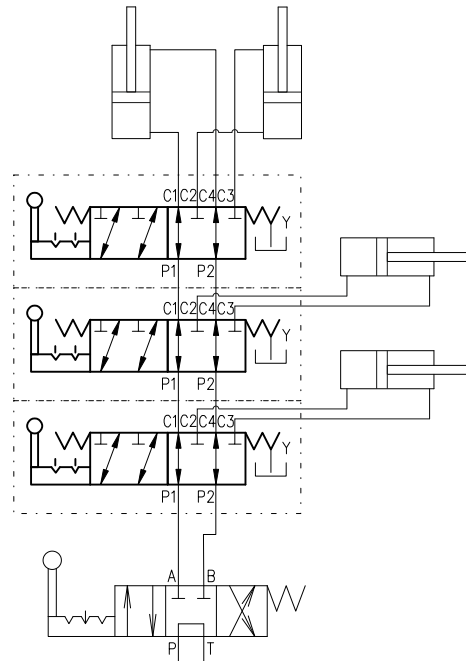

ORDERING CODE

6/2 FDV 06 ... 7 - FB

6-way , 2-position

Flow diverter

Nominal size - NG6

Functional symbol: **11A**
12A

Type of control: - manual

Modification

Detent: without detent - Omit
with detent - **D**

External drainage:

omit - without drainage
Y - with drainage

Connection threads:

G38 - G3/8"
G12 - G1/2"

Climatic executions:

N - normal
T - tropical

TECHNICAL DATA

GENERAL

DATA	UNIT	VALUE/RANGE
Installation position		optional
Max. ambient temperature	°C	-20...+50
Weight	kg	3,100
Lever angular movemet	°	19

HYDRAULIC

Max. pressure	MPa	31,5
with drainage		21
without drainage		
Rated flow	l/min	50
Hydraulic fluid-mineral oil:		
-viscosity	mm ² /s	10...800
-filtration degree	mm	0.025

CHARACTERISTICS

The same as for 6/2FDV06...1... - see page 6/11.

DIMENSIONS

All dimensions are shown in mm.

6/2FDV06...7-FB...Y

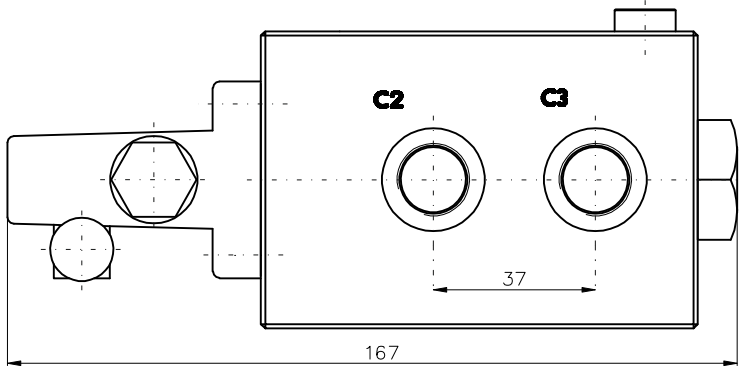
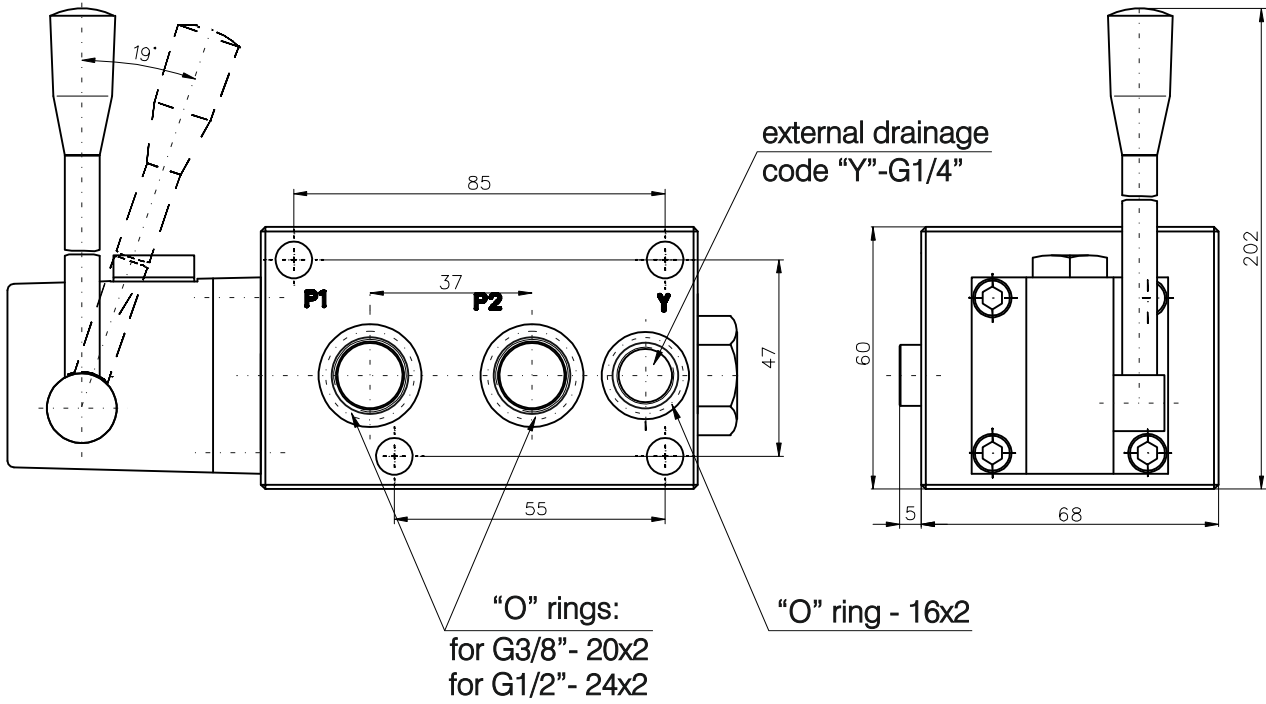

Always connect "Y" to the tank.

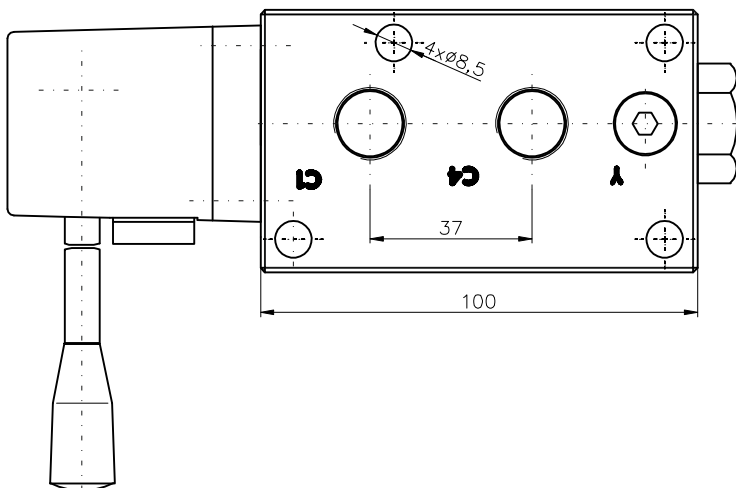

ASSEMBLY

All dimensions are shown in mm.

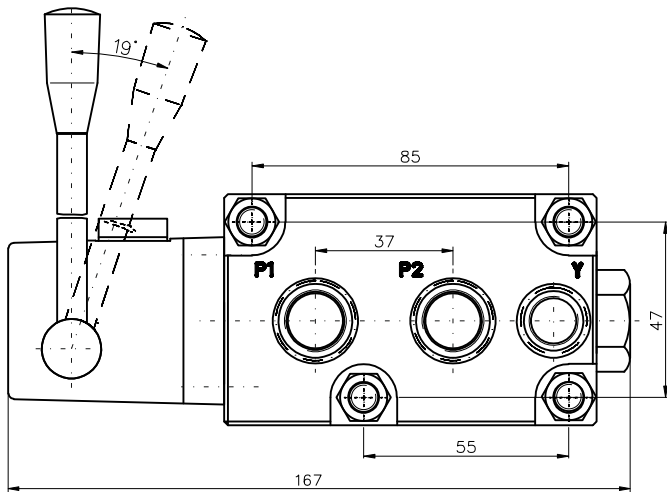

Here is shown 10-way valve
(3 pieces of single valves)
assembly for example:
3x6/2FDV0611A7-FBDNG38Y

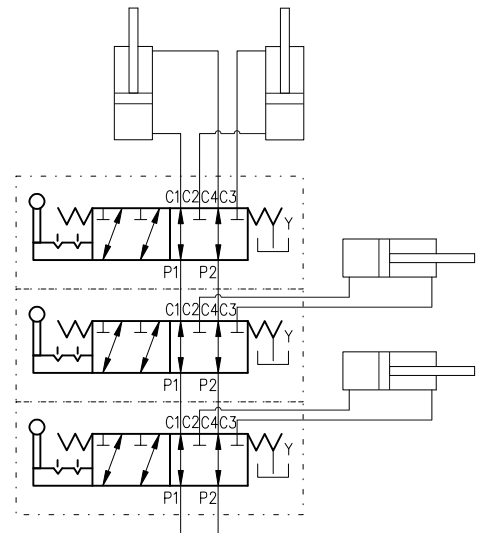
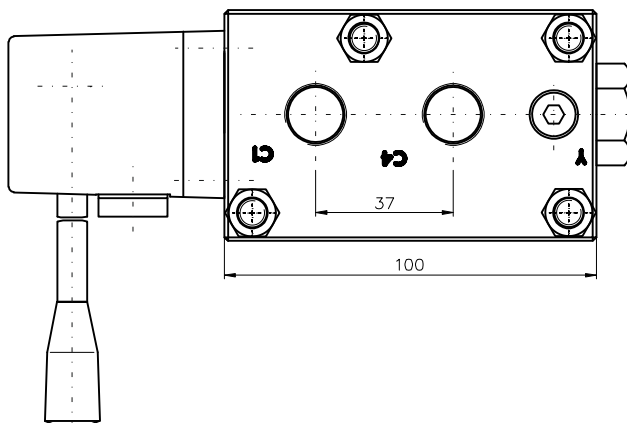
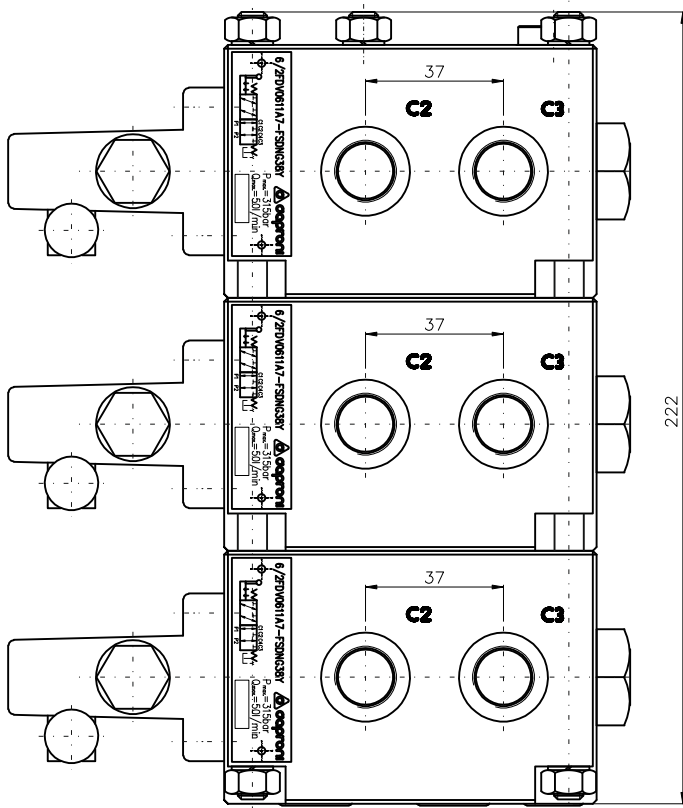

ACCESSORIES

STUDS

Studs: M8xL (4pcs per block).

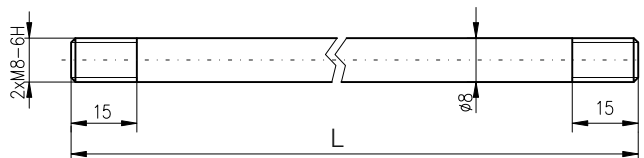

Number of sections	L(mm)
For 2 sections	135
For 3 sections	220
For 4 sections	286
For 5 sections	355

NUTS

Nuts: M8 DIN934/8 (8pcs per block). **Tightening torque - 8...10Nm.**

WASHERS

Washers: Ø8 DIN7980 (8pcs per block).

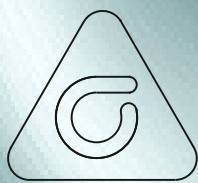

caproni

BULGARIA JOINT-STOCK COMPANY

**BULGARIA , 6100 KAZANLAK , 45 STOLETOV STR.
TEL.:+359/431/62 229 , +359/431/6132 ,
FAX:+359/431/62 230 , +359/431/63 134
E-MAIL:CAPRONI@CAPRONI.BG , WEB:HTTP://WWW.CAPRONI.BG**